



上海川源机械工程有限公司
Shanghai GSD Industrial Co.,Ltd

SMV(N)

不锈钢立式多级离心泵

SMV(N) stainless steel vertical multi-stage centrifugal pump



SMV(N) 不锈钢立式多级离心泵

SMV(N) stainless steel vertical multi-stage centrifugal pump

简介

SMV、SMVN为非自吸的立式多级离心泵。整个泵主要由电动机、电机座、泵体、机座等组成。泵进出口在同一条直线上。所有的泵均配用免维护的机械密封。

运转条件

- 输送液体：稀薄、非易燃易爆、不含有固体颗粒或纤维的液体，液体须不对泵材料造成化学性及机械损坏。当输送液体的密度或粘度大于水，必要时需采用相应的大功率电机。泵是否适用于某种特殊液体，取决于诸如液体的成分、温度、PH值等。
- 液体温度：-15℃ ~ 103℃。
- 环境温度：最高40℃。
- 最小进口压力：在下列情况下应计算进口压力：
 - 液体温度较高；
 - 流量明显比额定值大；
 - 液体所需的吸程很大；
 - 进口管路很长；
 - 进口条件比较差。
- 电动机：鼠笼式感应电动机，F级绝缘并符合IP54防护等级。50Hz标准电压：3Ø/380V。

General description

SMV, SMVN is a kind of non-self-priming vertical multiple-step centrifugal pump. The whole pump is composed of an motor, motor base, pump casing and feet etc. The inlet port and outlet port of the pump are at the same line. All pumps are equipped with free maintenance mechanical seals.

Operating conditions

- Delivery liquid: rarefied, non-inflammable and non-explosive liquid with no solid grain or fiber. Liquid shall not cause any chemical or mechanical damage to pump materials. When the density or viscosity of the delivered liquid is greater than that of water, it is necessary to adopt an electrical motor of correspondingly big power. Whether the pump is applicable for a special liquid or not depends on many factors such as ingredients, temperature and PH value of liquid.
- Liquid temperature: -15℃ ~ 103℃.
- Ambient temperature: maximum 40℃.
- Minimum inlet pressure: the inlet pressure shall be computed in case of following conditions: High temperature of liquid; flow rate is significantly greater than the rated value; suction lift required for liquid is very big; inlet pipeline is too long; inlet conditions are bad.
- Motor: squirrel cage induction motors, F Class insulation and in accordance with IP54. 50Hz standard voltage: 3Ø/380V.

型号说明 Type description

SMV(N) 32-3-1

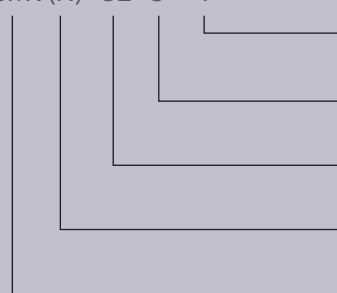

小叶轮数量

The number of smaller impeller

级数

The number of stage

额定流量 (m³/h)

Rated capacity(m³/h)

"N" 为具有全不锈钢的过流部件及过流通道

"N" means have stainless steel flow components and channels

不锈钢立式多级离心泵，仅泵头和机座为非不锈钢件

Stainless steel vertical multi-stage centrifugal pump. Only pump head and feet don't use stainless steel.

型谱图 Performance chart

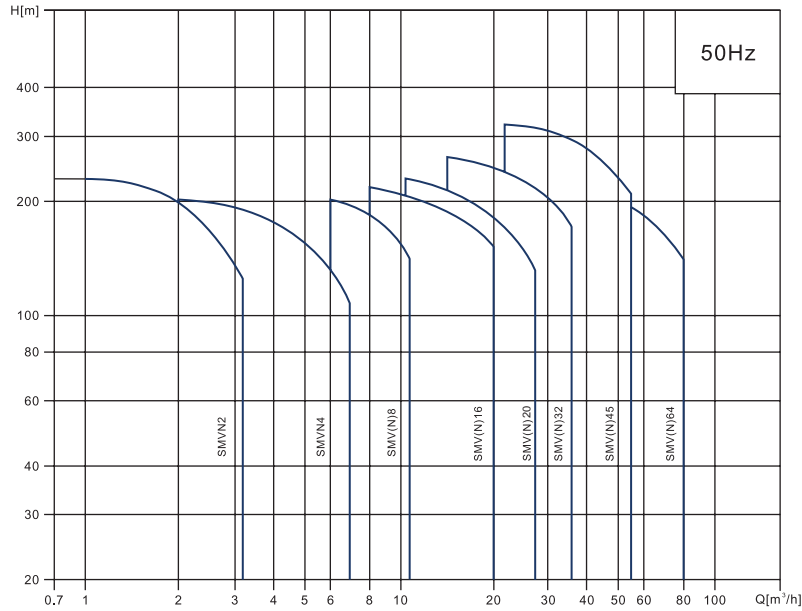

结构图 Construction

SMV

No.	名称 Name	材料 Material	AISI/ASTM
1	电机架 Motor base	铸铁 Cast iron	—
2	轴 Shaft	不锈钢 Stainless steel	AISI 431/304
3	泵头 Pump Body	铸铁 Cast iron	—
4	机械密封 Mechanical seal	多种材料* Various materials	—
5	叶轮 Impeller	不锈钢 Stainless steel	AISI 304
6	腔体 Chamber body	不锈钢 Stainless steel	AISI 304
7	外圆筒 Outside cylinder	不锈钢 Stainless steel	AISI 304
8	轴承 Bearing	—	—
9	颈环 Neck ring	石墨填充PTFE Carbon and PTFE	—
10	轴承环 Bearing ring	—	—
11	机座 Feet	铸铁 Cast iron	—
12	外圆筒O形圈 Flat O ring on excircle	EPDM或FKM EPDM/FKM	—
13	下轴承 Lower bearing	TC TC	—
14	底板 Base plate	铸铁 Cast iron	—
-	橡胶零件 Rubber parts	EPDM或FKM EPDM/FKM	—

SMVN

No.	名称 Name	材料 Material	AISI/ASTM
1	电机架 Motor base	铸铁 Cast iron	—
2	轴 Shaft	不锈钢 Stainless steel	AISI 304
3	泵头 Pump Body	不锈钢 Cast iron	AISI 304
4	机械密封 Mechanical seal	多种材料* Various materials	—
5	叶轮 Impeller	不锈钢 Stainless steel	AISI 304
6	腔体 Chamber body	不锈钢 Stainless steel	AISI 304
7	外圆筒 Outside cylinder	不锈钢 Stainless steel	AISI 304
8	轴承 Bearing	—	—
9	颈环 Neck ring	石墨填充PTFE Carbon and PTFE	—
10	轴承环 Bearing ring	—	—
11	机座 Feet	不锈钢 Cast iron	AISI 304
12	外圆筒O形圈 Flat O ring on excircle	EPDM或FKM EPDM/FKM	—
13	下轴承 Lower bearing	TC TC	—
14	底板 Base plate	铸铁 Cast iron	—
-	橡胶零件 Rubber parts	EPDM或FKM EPDM/FKM	—

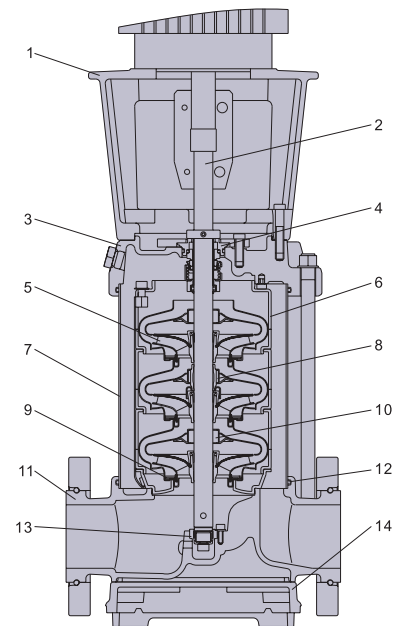

* 有不锈钢件及橡胶件等

* with stainless steel and rubber parts etc.

- 不锈钢或没有提供参照

- non-stainless steel or no reference provide

注：不同机型结构略有不同

Note: different model has a little differ

性能曲线及性能参数 Performance curve and performance parameter

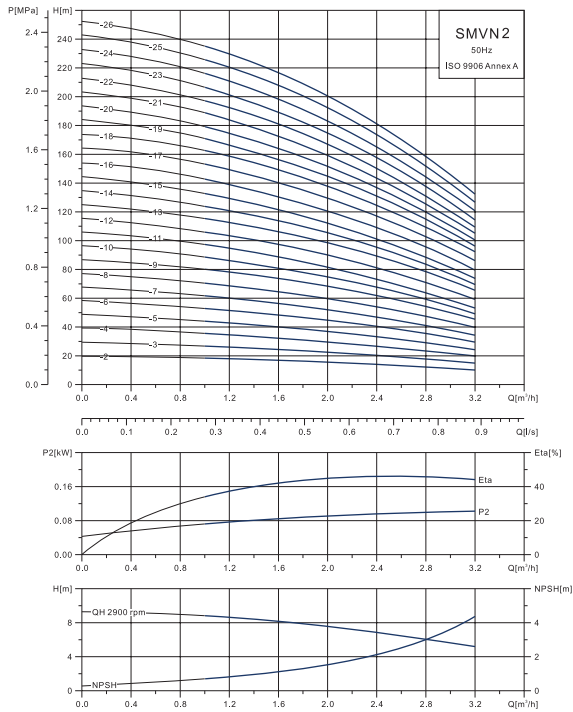

SMVN2

型号 Pump type	流量 Q(m³/h)							功率 Power (kW)
	扬程H(m)							
SMVN2-2	18	17	16	15	13	12	10	0.37
SMVN2-3	27	26	24	22	20	18	15	0.37
SMVN2-4	36	35	33	30	26	24	17	0.55
SMVN2-5	45	43	40	37	33	30	24	0.55
SMVN2-6	53	52	50	45	40	36	30	0.75
SMVN2-7	63	61	57	52	47	41	35	0.75
SMVN2-8	71	69	65	59	54	47	40	1.1
SMVN2-9	80	78	73	67	61	54	45	1.1
SMVN2-10	89	86	81	74	67	59	49	1.1
SMVN2-11	98	95	89	82	73	64	54	1.1
SMVN2-12	107	103	97	90	81	71	59	1.5
SMVN2-13	116	114	106	98	89	78	65	1.5
SMVN2-14	125	122	114	105	94	84	69	1.5
SMVN2-15	134	130	123	112	100	90	73	1.5
SMVN2-16	143	139	131	120	107	96	79	2.2
SMVN2-17	152	148	139	128	114	102	85	2.2
SMVN2-18	161	157	148	136	121	108	91	2.2
SMVN2-19	170	165	156	143	127	113	95	2.2
SMVN2-20	179	174	164	150	134	119	100	2.2
SMVN2-21	188	183	172	157	141	124	105	2.2
SMVN2-22	197	192	180	165	148	130	110	2.2
SMVN2-23	205	201	188	173	155	137	105	3.0
SMVN2-24	214	210	197	181	163	144	120	3.0
SMVN2-25	223	219	205	189	170	151	125	3.0
SMVN2-26	232	228	214	198	178	158	130	3.0

尺寸图 Dimensions

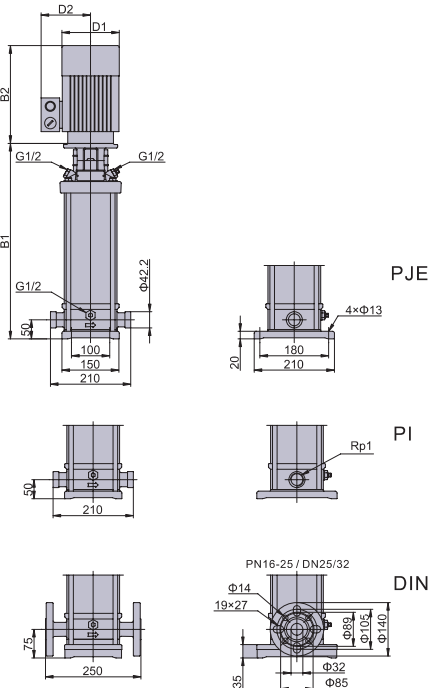

SMVN2

泵型号 Pump type	Dimensions(mm)					重量 Weight (kg)
	B1	B2	B1+B2	D1	D2	
SMVN2-2	245	220	465	140	110	20
SMVN2-3	263	220	483	140	110	21
SMVN2-4	281	220	501	140	110	23
SMVN2-5	299	220	519	140	110	24
SMVN2-6	322	250	572	160	125	25
SMVN2-7	340	250	590	160	125	27
SMVN2-8	358	250	608	160	125	28
SMVN2-9	376	250	626	160	125	29
SMVN2-10	394	250	644	160	125	30
SMVN2-11	412	250	662	160	125	31
SMVN2-12	447	290	737	180	125	32
SMVN2-13	465	290	755	180	125	33
SMVN2-14	483	290	773	180	125	34
SMVN2-15	501	290	791	180	125	35
SMVN2-16	519	290	809	180	125	49
SMVN2-17	537	290	827	180	125	50
SMVN2-18	555	290	845	180	125	51
SMVN2-19	573	290	863	180	125	52
SMVN2-20	591	290	881	180	125	53
SMVN2-21	609	290	899	180	125	54
SMVN2-22	627	290	917	180	125	55
SMVN2-23	653	330	983	190	140	57
SMVN2-24	671	330	1001	190	140	58
SMVN2-25	689	330	1019	190	140	59
SMVN2-26	707	330	1037	190	140	60

注：表格中所示B1尺寸为DIN法兰型机座的尺寸。
其余类型机座的B1尺寸，在此尺寸上减去25。

Note: The B1 dimension shown in the table is the dimension of DIN flange type feet.
The B1 dimension of other type feet shall be the result after the above dimension is deducted 25mm.

性能曲线及性能参数 Performance curve and performance parameter

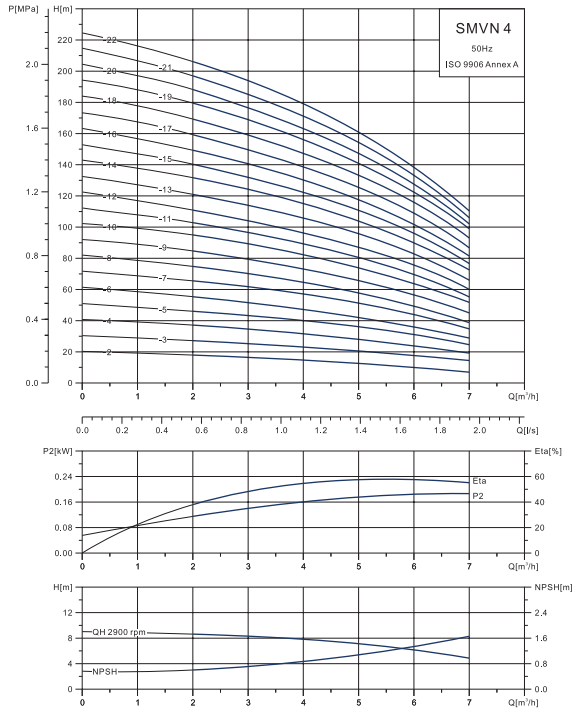

SMVN4

型号 Pump type	流量 $Q(m^3/h)$						功率 Power (kW)
	扬程 $H(m)$						
	2.0	3.0	4.0	5.0	6.0	7.0	
SMVN4-2	18	17	15	13	10	8	0.37
SMVN4-3	27	26	24	20	18	14	0.55
SMVN4-4	36	34	32	27	24	18	0.75
SMVN4-5	45	43	40	34	31	23	1.1
SMVN4-6	54	52	48	41	37	28	1.1
SMVN4-7	63	61	56	48	43	34	1.5
SMVN4-8	72	70	64	55	50	38	1.5
SMVN4-9	81	78	72	63	56	44	2.2
SMVN4-10	90	87	81	71	62	50	2.2
SMVN4-11	99	95	88	78	68	53	2.2
SMVN4-12	108	104	95	85	75	57	2.2
SMVN4-13	117	113	103	93	82	63	3.0
SMVN4-14	126	122	112	101	89	69	3.0
SMVN4-15	135	131	120	108	95	73	3.0
SMVN4-16	144	140	129	115	101	78	3.0
SMVN4-17	153	149	137	122	108	83	4.0
SMVN4-18	162	158	145	129	115	89	4.0
SMVN4-19	171	168	153	137	122	95	4.0
SMVN4-20	180	176	161	144	127	99	4.0
SMVN4-21	210	184	169	152	132	103	4.0
SMVN4-22	200	192	178	160	138	108	4.0

尺寸图 Dimensions

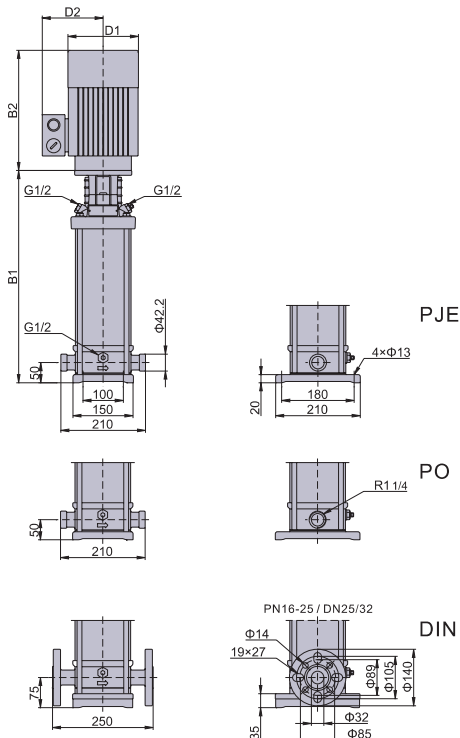

SMVN4

泵型号 Pump type	Dimensions(mm)					重量 Weight (kg)
	B1	B2	B1+B2	D1	D2	
SMVN4-2	263	220	483	140	110	20
SMVN4-3	290	220	510	140	110	21
SMVN4-4	322	250	572	160	125	23
SMVN4-5	349	250	599	160	125	24
SMVN4-6	376	250	626	160	125	25
SMVN4-7	420	290	710	180	125	29
SMVN4-8	447	290	737	180	125	30
SMVN4-9	474	290	764	180	125	32
SMVN4-10	501	290	791	180	125	33
SMVN4-11	528	290	818	180	125	34
SMVN4-12	555	290	845	180	125	35
SMVN4-13	590	330	920	190	140	47
SMVN4-14	617	330	947	190	140	48
SMVN4-15	644	330	974	190	140	49
SMVN4-16	671	330	1001	190	140	50
SMVN4-17	698	330	1028	220	150	60
SMVN4-18	725	330	1055	220	150	61
SMVN4-19	752	330	1082	220	150	62
SMVN4-20	779	330	1109	220	150	63
SMVN4-21	806	330	1136	220	150	64
SMVN4-22	833	330	1163	220	150	65

注：表格中所示B1尺寸为DIN法兰型机座的尺寸。
其余类型机座的B1尺寸，在此尺寸上减去25。

Note: The B1 dimension shown in the table is the dimension of DIN flange type feet.

The B1 dimension of other type feet shall be the result after the above dimension is deducted 25mm.



性能曲线及性能参数 Performance curve and performance parameter

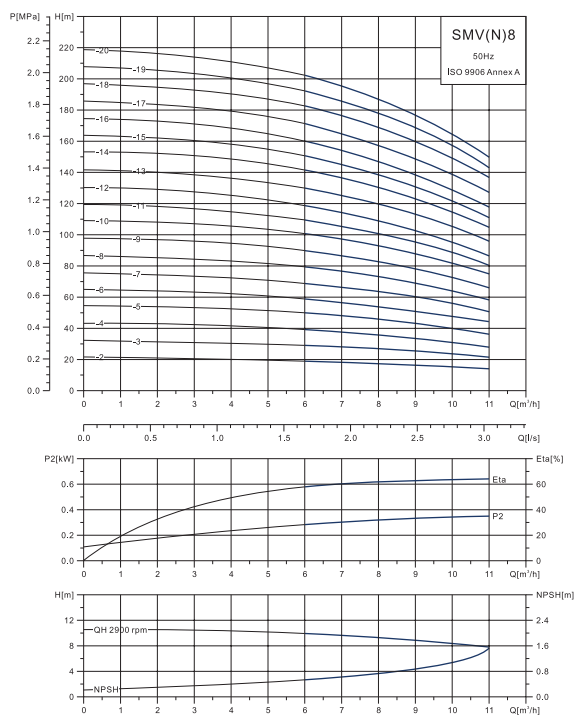

SMV(N)8

型号 Pump type	流量 Q(m³/h)						功率 Power (kW)
	扬程 H(m)						
SMV(N)8-2	20	19	18	17	16	14	0.75
SMV(N)8-3	30	29	28	26	24	21	1.1
SMV(N)8-4	40	39	37	35	32	28	1.5
SMV(N)8-5	50	48	46	44	41	36	2.2
SMV(N)8-6	60	58	55	53	49	43	2.2
SMV(N)8-7	70	68	64	61	57	50	3.0
SMV(N)8-8	80	78	74	70	65	58	3.0
SMV(N)8-9	90	87	83	79	72	66	4.0
SMV(N)8-10	100	97	92	88	80	74	4.0
SMV(N)8-11	110	106	101	96	88	80	4.0
SMV(N)8-12	120	116	110	105	97	86	4.0
SMV(N)8-13	130	126	119	114	105	95	5.5
SMV(N)8-14	140	136	129	123	113	105	5.5
SMV(N)8-15	150	145	138	131	121	111	5.5
SMV(N)8-16	160	155	147	140	130	117	5.5
SMV(N)8-17	170	165	156	149	138	126	7.5
SMV(N)8-18	180	175	166	158	146	136	7.5
SMV(N)8-19	190	184	175	166	154	142	7.5
SMV(N)8-20	200	194	185	175	162	149	7.5

尺寸图 Dimensions

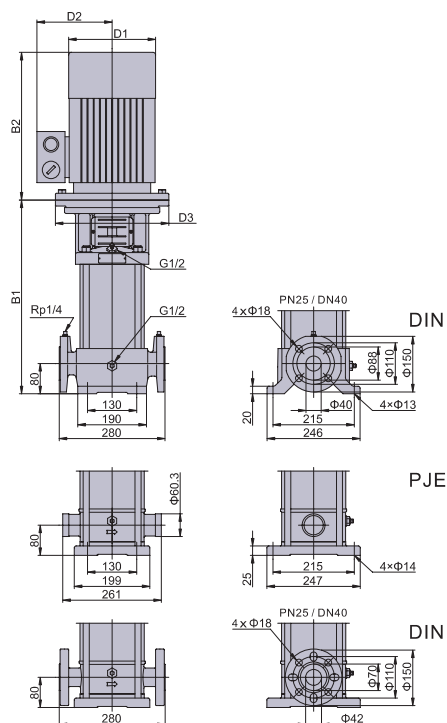

SMV(N)8

泵型号 Pump type	Dimensions(mm)						重量 Weight (kg)
	B1	B2	B1+B2	D1	D2	D3	
SMV(N)8-2	355	250	605	160	125	-	35
SMV(N)8-3	385	250	635	160	125	-	35
SMV(N)8-4	427	290	717	180	125	-	45
SMV(N)8-5	457	290	747	180	125	-	50
SMV(N)8-6	487	290	777	180	125	-	50
SMV(N)8-7	523	330	853	190	140	-	55
SMV(N)8-8	553	330	883	190	140	-	55
SMV(N)8-9	583	330	913	220	150	-	55
SMV(N)8-10	613	330	943	220	150	-	55
SMV(N)8-11	643	330	973	220	150	-	60
SMV(N)8-12	673	330	1003	220	150	-	60
SMV(N)8-13	720	420	1140	260	210	300	85
SMV(N)8-14	750	420	1170	260	210	300	85
SMV(N)8-15	780	420	1200	260	210	300	85
SMV(N)8-16	810	420	1230	260	210	300	85
SMV(N)8-17	840	420	1260	260	210	300	90
SMV(N)8-18	870	420	1290	260	210	300	90
SMV(N)8-19	900	420	1320	260	210	300	90
SMV(N)8-20	930	420	1350	260	210	300	90

性能曲线及性能参数 Performance curve and performance parameter

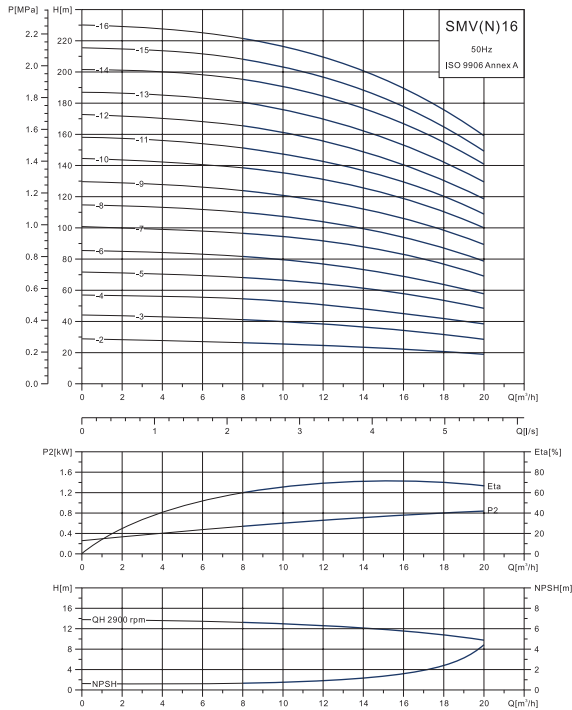

SMV(N)16

型号 Pump type	流量 Q(m³/h)							功率 Power (kW)
	扬程H(m)							
	8	10	12	14	16	18	20	
SMV(N)16-2	28	27	26	25	23	21	18	2.2
SMV(N)16-3	42	41	39	37	35	32	27	3.0
SMV(N)16-4	56	54	52	50	47	44	37	4.0
SMV(N)16-5	69	68	65	62	59	54	47	5.5
SMV(N)16-6	83	81	78	75	70	64	56	5.5
SMV(N)16-7	97	95	92	87	82	75	68	7.5
SMV(N)16-8	111	108	105	100	94	86	77	7.5
SMV(N)16-9	120	122	118	112	106	97	88	11
SMV(N)16-10	139	136	131	125	118	108	99	11
SMV(N)16-11	153	149	144	137	129	118	108	11
SMV(N)16-12	167	163	157	150	141	129	117	11
SMV(N)16-13	180	176	170	162	153	140	128	15
SMV(N)16-14	194	190	184	175	165	151	139	15
SMV(N)16-15	208	203	197	187	177	162	148	15
SMV(N)16-16	222	217	210	200	189	173	158	15

尺寸图 Dimensions

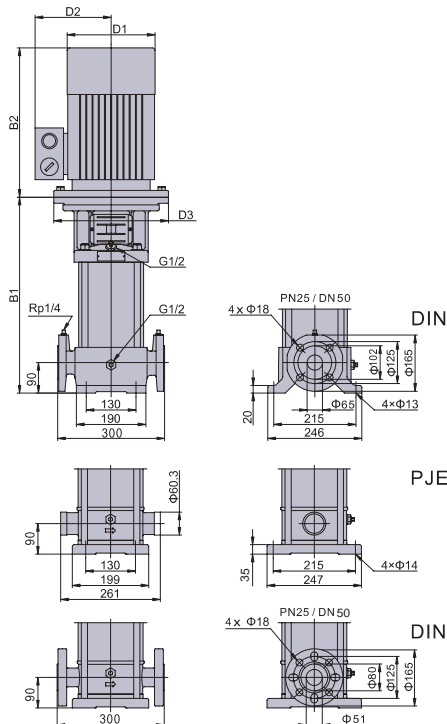

SMV(N)16

泵型号 Pump type	Dimensions(mm)						重量 Weight (kg)
	B1	B2	B1+B2	D1	D2	D3	
SMV(N)16-2	407	290	697	180	125	-	50
SMV(N)16-3	458	330	788	190	140	-	55
SMV(N)16-4	503	330	833	220	150	-	60
SMV(N)16-5	565	420	985	260	210	300	80
SMV(N)16-6	610	420	1030	260	210	300	85
SMV(N)16-7	655	420	1075	260	210	300	90
SMV(N)16-8	700	420	1120	260	210	300	90
SMV(N)16-9	775	500	1275	330	260	350	125
SMV(N)16-10	820	500	1320	330	260	350	125
SMV(N)16-11	865	500	1365	330	260	350	130
SMV(N)16-12	910	500	1410	330	260	350	130
SMV(N)16-13	955	500	1455	330	260	350	175
SMV(N)16-14	1000	500	1500	330	260	350	175
SMV(N)16-15	1045	500	1545	330	260	350	180
SMV(N)16-16	1090	500	1590	330	260	350	180



性能曲线及性能参数 Performance curve and performance parameter

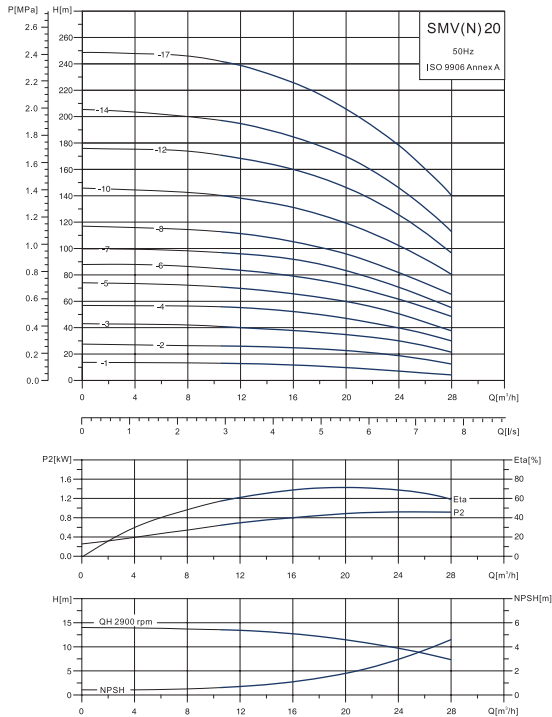

SMV(N)20

型号 Pump type	流量 $Q(m^3/h)$						功率 Power (kW)
	10.5	14	18	20	24	28	
SMV(N)20-1	13	12	11	9	8	6	1.1
SMV(N)20-2	27	26	24	22	19	14	2.2
SMV(N)20-3	42	40	37	35	30	23	4.0
SMV(N)20-4	56	54	50	47	41	32	5.5
SMV(N)20-5	70	67	62	59	50	39	5.5
SMV(N)20-6	84	81	75	72	61	49	7.5
SMV(N)20-7	98	94	88	83	71	56	7.5
SMV(N)20-8	112	109	101	97	83	65	11
SMV(N)20-10	140	136	126	120	103	81	11
SMV(N)20-12	170	164	153	145	125	98	15
SMV(N)20-14	197	190	177	168	144	113	15
SMV(N)20-17	241	233	217	206	178	141	18.5

尺寸图 Dimensions

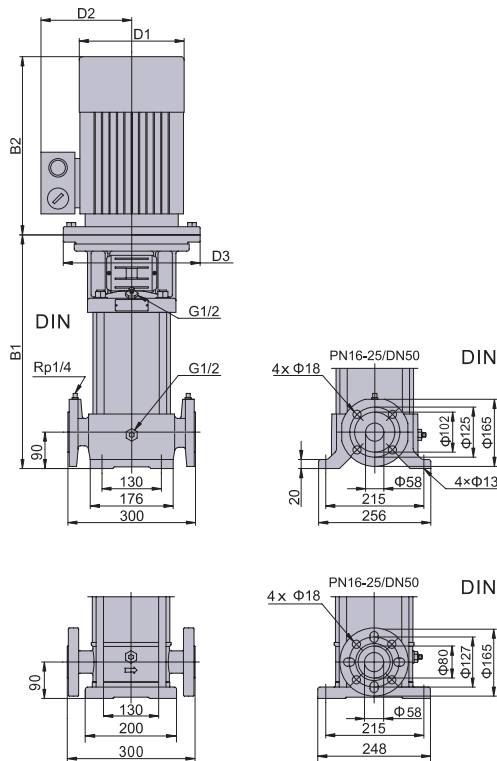

SMV(N)20

泵型号 Pump type	Dimensions (mm)						重量 Weight (kg)
	B1	B2	B1+B2	D1	D2	D3	
SMV(N)20-1	400	250	650	160	125	-	42
SMV(N)20-2	415	290	705	180	125	-	50
SMV(N)20-3	465	330	795	220	150	-	66
SMV(N)20-4	542	420	962	260	210	300	88
SMV(N)20-5	587	420	1007	260	210	300	90
SMV(N)20-6	632	420	1052	260	210	300	93
SMV(N)20-7	677	420	1097	260	210	300	95
SMV(N)20-8	799	500	1299	330	260	350	141
SMV(N)20-10	889	500	1389	330	260	350	144
SMV(N)20-12	979	500	1479	330	260	350	154
SMV(N)20-14	1069	500	1569	330	260	350	157
SMV(N)20-17	1204	500	1754	380	310	350	177

性能曲线及性能参数 Performance curve and performance parameter

SMV(N)32

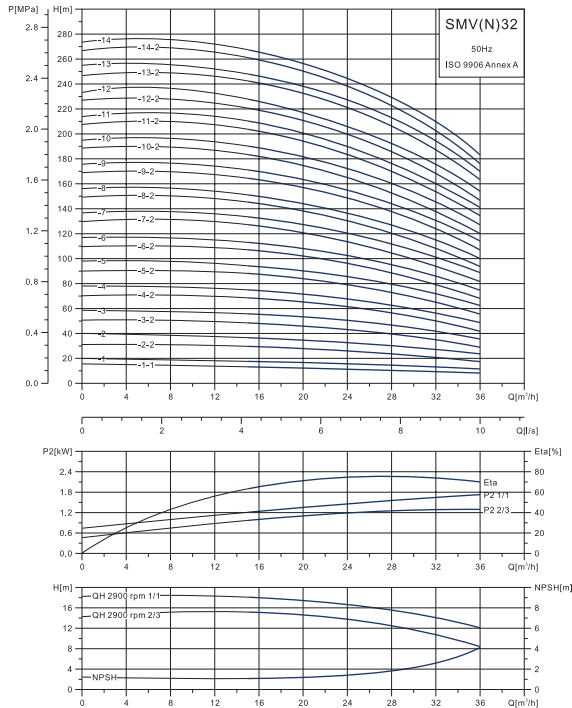

型号 Pump type	流量 Q(m³/h)		扬程 H(m)						功率 Power (kW)
	15	16	20	24	28	32	36		
SMV(N)32-1-1	16	15	13	12	11	10	7	1.5	
SMV(N)32-1	18	17	16	15	14	13	10	2.2	
SMV(N)32-2-2	32	31	30	27	25	22	14	3.0	
SMV(N)32-2	37	36	35	32	31	28	22	4.0	
SMV(N)32-3-2	50	49	47	44	40	36	27	5.5	
SMV(N)32-3	56	55	53	50	47	42	33	5.5	
SMV(N)32-4-2	68	67	65	62	56	50	37	7.5	
SMV(N)32-4	75	74	71	67	62	56	45	7.5	
SMV(N)32-5-2	88	87	85	80	73	66	51	11	
SMV(N)32-5	94	93	90	86	79	72	57	11	
SMV(N)32-6-2	107	106	102	96	89	79	62	11	
SMV(N)32-6	114	112	107	102	95	86	68	11	
SMV(N)32-7-2	127	125	121	114	106	94	75	15	
SMV(N)32-7	133	131	126	119	112	102	82	15	
SMV(N)32-8-2	145	143	137	131	121	109	85	15	
SMV(N)32-8	151	149	144	136	128	115	92	15	
SMV(N)32-9-2	165	163	157	149	138	125	98	18.5	
SMV(N)32-9	172	170	163	155	146	132	106	18.5	
SMV(N)32-10-2	184	182	175	165	154	138	110	18.5	
SMV(N)32-10	190	188	181	172	159	145	117	18.5	
SMV(N)32-11-2	204	202	194	184	171	154	123	22	
SMV(N)32-11	210	208	200	190	177	161	130	22	
SMV(N)32-12-2	222	220	212	201	187	168	135	22	
SMV(N)32-12	226	224	217	207	193	176	142	22	
SMV(N)32-13-2	244	242	233	222	207	187	151	30	
SMV(N)32-13	250	248	238	227	213	193	158	30	
SMV(N)32-14-2	264	260	252	237	222	202	163	30	
SMV(N)32-14	268	265	256	244	228	208	170	30	

尺寸图 Dimensions

SMV(N)32

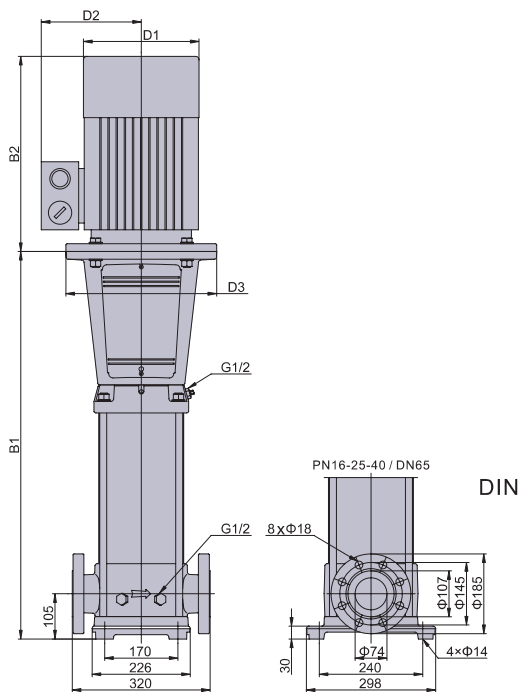

泵型号 Pump type	Dimensions(mm)						重量 Weight (kg)
	B1	B2	B1+B2	D1	D2	D3	
SMV(N)32-1-1	505	290	795	180	125	140	80
SMV(N)32-1	505	290	795	180	125	140	85
SMV(N)32-2-2	575	330	905	190	140	160	95
SMV(N)32-2	575	330	905	220	150	160	105
SMV(N)32-3-2	645	420	1065	260	210	300	115
SMV(N)32-3	645	420	1065	260	210	300	115
SMV(N)32-4-2	715	420	1135	260	210	300	125
SMV(N)32-4	715	420	1135	260	210	300	125
SMV(N)32-5-2	895	500	1395	330	260	350	165
SMV(N)32-5	895	500	1395	330	260	350	165
SMV(N)32-6-2	965	500	1465	330	260	350	170
SMV(N)32-6	965	500	1465	330	260	350	170
SMV(N)32-7-2	1035	500	1535	330	260	350	205
SMV(N)32-7	1035	500	1535	330	260	350	205
SMV(N)32-8-2	1105	500	1605	330	260	350	210
SMV(N)32-8	1105	500	1605	330	260	350	210
SMV(N)32-9-2	1175	550	1725	380	310	350	220
SMV(N)32-9	1175	550	1725	380	310	350	220
SMV(N)32-10-2	1245	550	1795	380	310	350	225
SMV(N)32-10	1245	550	1795	380	310	350	225
SMV(N)32-11-2	1315	600	1915	380	310	350	285
SMV(N)32-11	1315	600	1915	380	310	350	285
SMV(N)32-12-2	1385	600	1985	380	310	350	285
SMV(N)32-12	1385	600	1985	380	310	350	285
SMV(N)32-13-2	1455	660	2115	420	350	400	370
SMV(N)32-13	1455	660	2115	420	350	400	370
SMV(N)32-14-2	1525	660	2185	420	350	400	375
SMV(N)32-14	1525	660	2185	420	350	400	375



性能曲线及性能参数 Performance curve and performance parameter

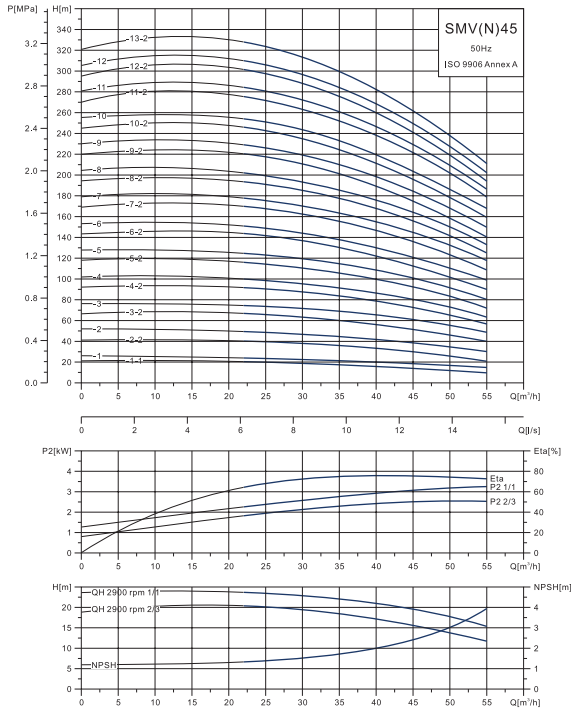

SMV(N)45

型号 Pump type	流量 Q(m³/h)								功率 Power (kW)
	扬程 H(m)								
SMV(N)45-1-1	21	20	19	18	17	16	13	11	3.0
SMV(N)45-1	25	24	23	22	21	19	17	15	4.0
SMV(N)45-2-2	42	40	38	37	34	31	27	23	5.5
SMV(N)45-2	50	48	47	45	42	38	36	32	7.5
SMV(N)45-3-2	68	66	65	60	56	52	47	39	11
SMV(N)45-3	74	72	72	68	65	59	54	48	11
SMV(N)45-4-2	93	91	89	84	78	72	65	56	15
SMV(N)45-4	100	98	96	92	87	80	73	65	15
SMV(N)45-5-2	118	116	112	108	102	93	84	74	18.5
SMV(N)45-5	126	124	120	115	109	101	92	80	18.5
SMV(N)45-6-2	144	142	137	132	123	114	103	89	22
SMV(N)45-6	152	150	145	138	131	122	111	97	22
SMV(N)45-7-2	171	168	164	156	147	136	124	109	30
SMV(N)45-7	178	175	171	164	155	144	132	116	30
SMV(N)45-8-2	195	192	187	178	169	156	142	125	30
SMV(N)45-8	203	200	194	187	176	164	150	133	30
SMV(N)45-9-2	220	217	211	202	190	176	158	140	30
SMV(N)45-9	229	226	219	211	198	187	170	150	37
SMV(N)45-10-2	246	243	235	226	212	196	178	158	37
SMV(N)45-10	254	251	244	233	220	205	188	165	37
SMV(N)45-11-2	276	273	265	253	238	221	201	178	45
SMV(N)45-11	284	281	272	261	246	229	210	187	45
SMV(N)45-12-2	302	298	289	276	260	242	220	195	45
SMV(N)45-12	310	306	296	285	269	250	229	204	45
SMV(N)45-13-2	327	323	313	300	283	262	239	212	45

尺寸图 Dimensions

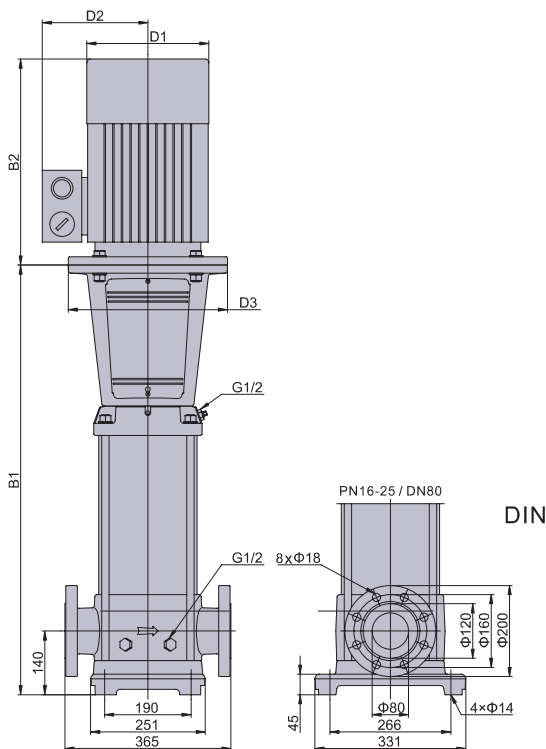

SMV(N)45

泵型号 Pump type	Dimensions(mm)						重量 Weight (kg)
	B1	B2	B1+B2	D1	D2	D3	
SMV(N)45-1-1	558	330	888	190	140	160	100
SMV(N)45-1	558	330	888	220	150	160	110
SMV(N)45-2-2	638	420	1058	260	210	300	120
SMV(N)45-2	638	420	1058	260	210	300	125
SMV(N)45-3-2	828	500	1328	330	260	350	165
SMV(N)45-3	828	500	1328	330	260	350	165
SMV(N)45-4-2	908	500	1408	330	260	350	205
SMV(N)45-4	908	500	1408	330	260	350	205
SMV(N)45-5-2	988	550	1538	380	310	350	215
SMV(N)45-5	988	550	1538	380	310	350	215
SMV(N)45-6-2	1068	600	1668	380	310	350	275
SMV(N)45-6	1068	600	1668	380	310	350	275
SMV(N)45-7-2	1148	660	1808	420	350	400	355
SMV(N)45-7	1148	660	1808	420	350	400	355
SMV(N)45-8-2	1228	660	1888	420	350	400	360
SMV(N)45-8	1228	660	1888	420	350	400	360
SMV(N)45-9-2	1308	660	1968	420	350	400	365
SMV(N)45-9	1308	660	1968	420	350	400	365
SMV(N)45-10-2	1388	660	2048	420	350	400	390
SMV(N)45-10	1388	660	2048	420	350	400	390
SMV(N)45-11-2	1468	710	2178	470	375	450	455
SMV(N)45-11	1468	710	2178	470	375	450	455
SMV(N)45-12-2	1556	710	2266	470	375	450	460
SMV(N)45-12	1556	710	2266	470	375	450	460
SMV(N)45-13-2	1636	710	2346	470	375	450	465

性能曲线及性能参数 Performance curve and performance parameter

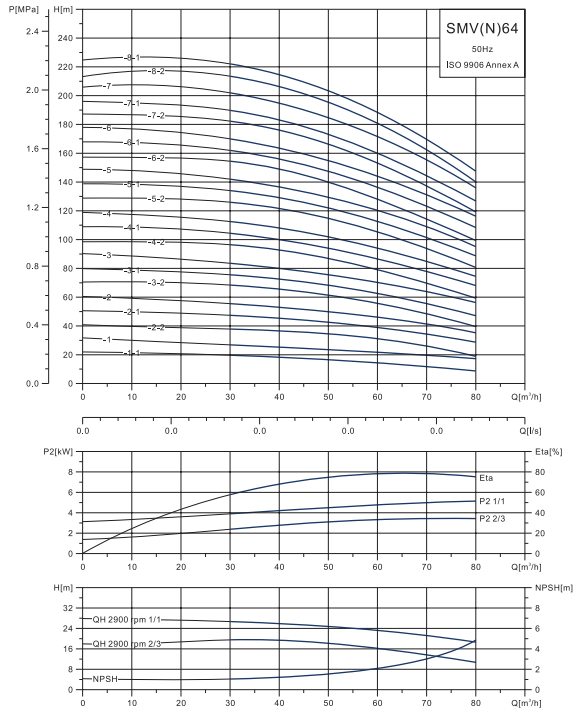

SMV(N)64

型号 Pump type	流量 Q(m³/h)						功率 Power (kW)
	扬程 H(m)						
SMV(N)64-1-1	20	18	16	14	12	9	4.0
SMV(N)64-1	28	26	24	22	20	17	5.5
SMV(N)64-2-2	40	38	36	31	26	19	7.5
SMV(N)64-2-1	48	46	43	39	34	28	11
SMV(N)64-2	55	52	49	46	42	36	11
SMV(N)64-3-2	69	66	61	55	48	40	15
SMV(N)64-3-1	75	72	68	63	56	48	15
SMV(N)64-3	85	80	76	71	64	55	18.5
SMV(N)64-4-2	96	93	88	79	70	59	18.5
SMV(N)64-4-1	104	100	95	88	78	68	22
SMV(N)64-4	111	107	102	94	86	75	22
SMV(N)64-5-2	126	122	114	106	94	80	30
SMV(N)64-5-1	134	129	122	113	102	88	30
SMV(N)64-5	141	136	129	120	110	96	30
SMV(N)64-6-2	154	149	140	129	115	100	30
SMV(N)64-6-1	162	156	148	137	125	108	37
SMV(N)64-6	170	164	155	145	132	116	37
SMV(N)64-7-2	182	177	166	153	138	120	37
SMV(N)64-7-1	190	184	173	160	146	127	37
SMV(N)64-7	202	195	185	172	155	137	45
SMV(N)64-8-2	214	207	196	181	162	140	45
SMV(N)64-8-1	223	215	203	189	170	149	45

尺寸图 Dimensions

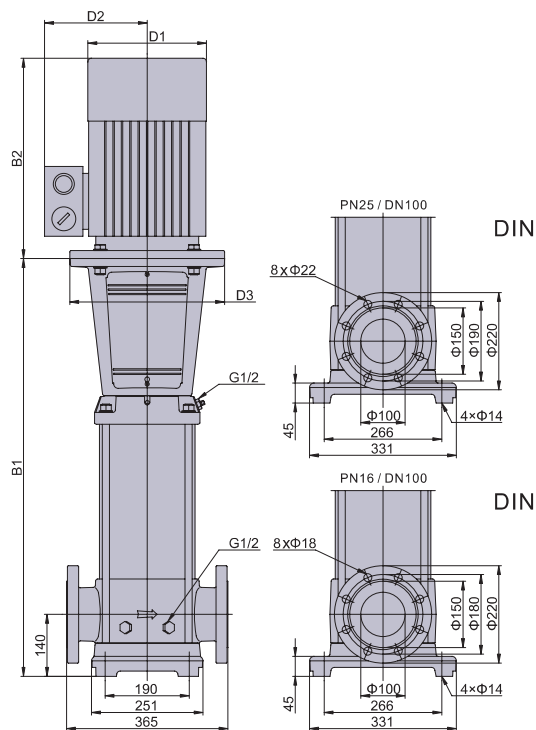

SMV(N)64

泵型号 Pump type	Dimensions(mm)						重量 Weight (kg)
	B1	B2	B1+B2	D1	D2	D3	
SMV(N)64-1-1	561	330	891	220	150	160	105
SMV(N)64-1	561	420	981	260	210	300	120
SMV(N)64-2-2	644	420	1064	260	210	300	130
SMV(N)64-2-1	754	500	1254	330	260	350	165
SMV(N)64-2	754	500	1254	330	260	350	165
SMV(N)64-3-2	836	500	1336	330	260	350	205
SMV(N)64-3-1	836	500	1336	330	260	350	205
SMV(N)64-3	836	550	1386	380	310	350	215
SMV(N)64-4-2	919	550	1469	380	310	350	215
SMV(N)64-4-1	919	600	1519	380	310	350	270
SMV(N)64-4	919	600	1519	380	310	350	270
SMV(N)64-5-2	1001	660	1661	420	350	400	350
SMV(N)64-5-1	1001	660	1661	420	350	400	350
SMV(N)64-5	1001	660	1661	420	350	400	350
SMV(N)64-6-2	1084	660	1744	420	350	400	355
SMV(N)64-6-1	1084	660	1744	420	350	400	375
SMV(N)64-6	1084	660	1744	420	350	400	375
SMV(N)64-7-2	1166	660	1826	420	350	400	380
SMV(N)64-7-1	1166	660	1826	420	350	400	380
SMV(N)64-7	1166	710	1876	470	375	450	445
SMV(N)64-8-2	1248	710	1958	470	375	450	450
SMV(N)64-8-1	1248	710	1958	470	375	450	450



欢迎索取以下产品型录



泵系列

- 潜水泵系列
- 陆上泵系列
- 特种泵系列
- 消防泵系列



搅拌推流系列

- 搅拌机系列
- 推流器系列



供氧曝气系列

- 曝气机系列
- 曝气盘系列
- 曝气管系列



风机系列

- 三叶罗茨鼓风机系列
- 增压罗茨鼓风机系列



污泥处理设备 及其他

- 固液分离系列
- 泡药设备
- 输送设备



上海川源机械工程有限公司
Shanghai GSD Industrial Co.,Ltd

免费咨询电话

800-820-1977

本型录内容如有变更，恕不另行通知。
We reserve the right to change content without notice.